

Thank you for purchasing the Tekelek Ultrasonic LoRaWAN sensor which uses ultrasonic technology to measure the liquid level of your tank and then communicates this data to a LoRaWAN network.



**STEP 1: Activation**

The Ultrasonic LoRaWAN sensor works in conjunction with a LoRaWAN network and a connected platform and before activation must first be registered with both. Access to the LoRaWAN backend server is required to verify that the unit has correctly joined the network. See User Manual for further details.

Ensure that the LoRaWAN™ network is within communication range of the sensor. This should occur before the sensor is physically fitted onto the Tank. In areas where the signal is too weak, such as underground installations, the external antenna option may be required. If this is the case, the antenna will need to be connected prior to activation, see [Appendix 6](#).

- Place the sensor as close as possible to the point of installation, press the button for 1 second to connect to the LoRaWAN network and upload a status message.
- The LED will stay illuminated as the sensor registers:
  - Red LED flashing = The sensor is registering & connecting for the first time. (Sensor is shipped in dormant state).
  - Green LED flashing = The sensor is already registered. The connection process will take between 20 & 40 seconds.
- After the connection has completed, the LED will flash on & off (to indicate whether the connection was a success or failure).

**LED Patterns**

- Press and hold the button for approximately 1 second, until the LED turns green.
- Wait approximately 10-20 seconds and observe if the LED flashes green or red.

See the following for description of Green/Red LED flash codes.

**LED Radio Signal Strength Flash Codes:**

LED Pattern	Function
Green X 3 Flashes	Excellent signal strength
Green X 2 Flashes	Good signal strength
Green X 1 Flash	Adequate signal strength
Alternate Green/Red Flash	Weak signal strength

**Weak signal strength:** Try 5 times and if this response is stable then it's deemed adequate. If the sensor shows some double red flashes during this signal strength test - then an external antenna should be tried. It may need to be elevated for best performance.

**LED Error Flash Codes:**

LED Pattern	Function
Red X 1 Flash	Device registered with an incorrect AppKey.
Red X 2 Flashes	No response from LoRaWAN network
Red X 3 Flashes	General Error. Please try again. If the error persists, contact the supplier for support.
Red X 5 Flashes	Maximum number of allowed button presses exceeded (up to 10 button presses per hour allowed).



**STEP 2: Installation**

The following outlines the Ultrasonic LoRaWAN sensor mounting options.

- The sensor must sit in a vertical position on top of the tank and be fitted such that the sensor has a clear path to the tank contents. Position it so that there are no internal obstructions that may interfere with the ultrasonic signal.

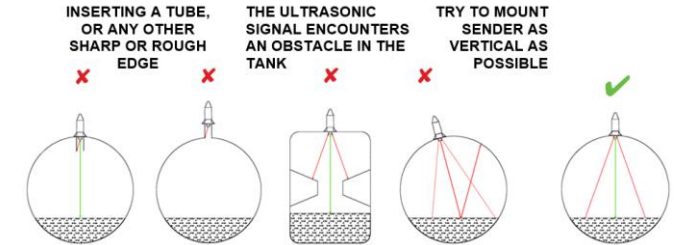

- If obstacles cannot be avoided, then a waveguide may be required. Please refer to [Appendix 1](#) for further details.
- Locate a suitably positioned threaded opening on the top of the tank to hold the sensor.
  - The sensor will fit directly into threaded 2" BSP (British Standard Pipe) existing tank connections.
  - Ensure that the rubber seal is placed, and that the sensor is screwed correctly into the tank. Do not over-tighten!
- For tanks that do not contain a suitably positioned threaded opening on the top of the tank to hold the sensor, please refer to [Appendix 2 & 5](#).

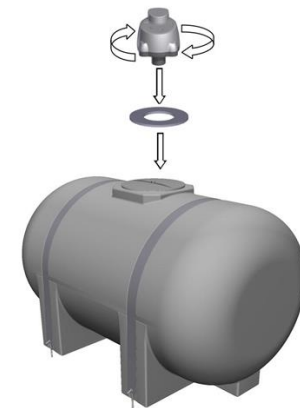

## Appendix 1: Standard Waveguide

- For the waveguide option, source a suitable pipe to act as the waveguide. This pipe should have an outer diameter of 40mm. The recommended pipe material is PVC (domestic waste pipe is often used). Other materials are possible but should be checked for chemical resistance to fuel oil.

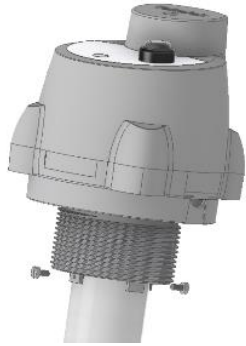

- The pipe should be cleanly cut to length. The length required should be measured from the top of the tank (where the sensor is to be mounted) to that of the fuel outlet point (as shown).



**Note:** The bottom of the pipe should be a minimum of 5cm from the base (floor) of the tank to prevent it from touching in the case of tank dimensional changes due to temperature etc.

- The waveguide pipe should be securely attached via the two screws provided and hand tightened (Note: over-tightening the screws can damage the plastic). Drill a 1.5mm pilot hole in 2 opposite tabs of the adaptor to guide the screws.
- Care should be taken to keep the sensor and pipe vertically aligned and supported, while fitting during the installation.
- Insert the rubber seal ring (supplied) and position it on the face of the adaptor that is screwed onto the top of the tank.

- Insert the whole assembly carefully into the tank, taking care not to loosen the pipe, and fit into position. Hand tighten the assembly until the rubber seal locks into position.
- The use of a waveguide requires that the Ultrasonic LoRaWAN sensor be configured with a waveguide ultrasonic profile from the LoRaWAN server.

**Note:** the default sensor configuration is non-waveguide mode and the measurements will be inaccurate unless a waveguide configuration mode is used.

**Note:** The use of this Waveguide option is limited to a range of 3m and not 4m as per standard operation.

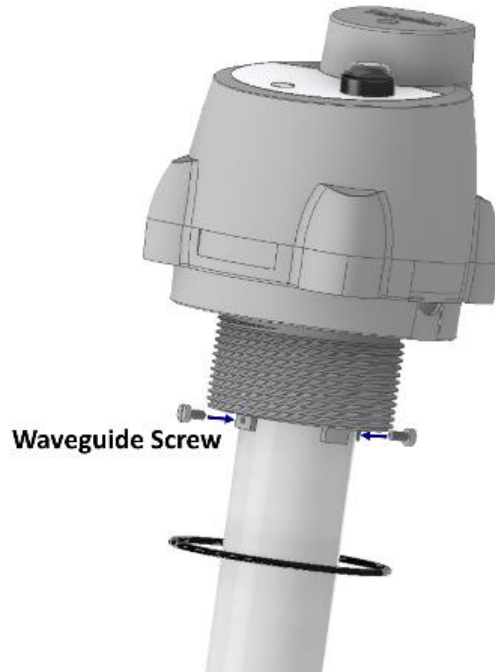

## Appendix 2: Drilling procedure for Mounting adaptor.

- Choose a flat spot on the top of the tank.
- Use a 45.5mm tapping drill to drill a 1 1/2" BSP hole on the surface of the tank.
- Place the foam gasket over the hole followed by the mounting adaptor.
- Place mounting plate seal in the required groove of the mounting adaptor.
- Tighten on to tank with 2 stainless steel self-tapping, counter sunk screws, supplied. Do not over tighten!
- Screw the sensor into the adaptor. Ensure that the sensor is vertical on the tank and screwed correctly into the base and that the threads have not crossed, to give a secure seal.

**Note:** Some threading will still be visible after the sensor has been secured.



### Appendix 3: Multi-Thread Adaptor

- For tanks that do not contain a suitably positioned threaded opening on the top of the tank to hold the sensor, the pre-existing 2" adaptor will need to be removed from the sensor and replaced with a multi-thread adaptor, shown below.
- Remove the 2" adaptor by unscrewing the M3.5x10 Pozi screws x 4 that attach it to the base of the ultrasonic sensor.
- The Multi-Thread adaptor should be attached to the pairing adaptor using No.8x13mm Pozi screws x 2.

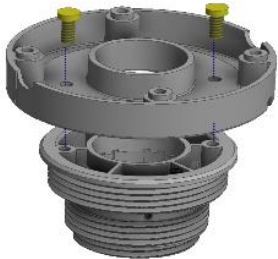

- The pairing adaptor should then be attached to the ultrasonic sensor base using the M3.5x10 Pozi screws x 4 that previously held the 2" adaptor in place.

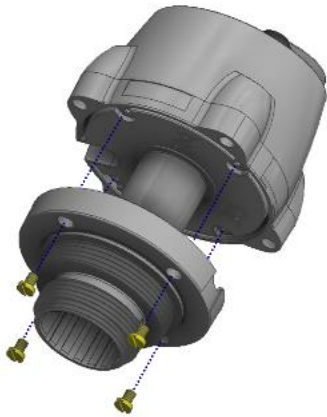

**Note:** This adaptor can also be used with the waveguide option but will require a 36mm pipe. The waveguide pipe should be securely attached via the two grub screws provided and hand tightened with an M1.5 Allen key (Note: over-tightening the grub screws can damage the plastic).

### Appendix 4: Multi-Thread Adaptor Waveguide

- For the waveguide option when using the Multi-Thread adaptor, source a suitable pipe to act as the waveguide. This pipe should conform the dimensions in the figure below in order to fit the sensor. The recommended pipe material is PVC (domestic waste pipe is often used). Other materials are possible but should be checked for chemical resistance to fuel oil.
- Cross-section of waveguide pipe assembly:

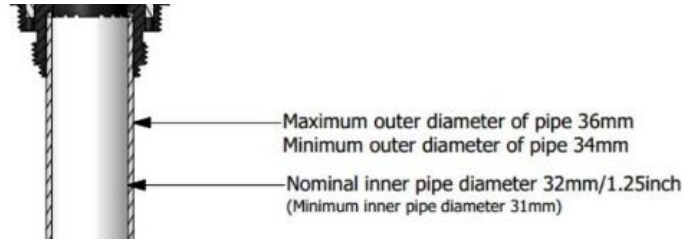

- The pipe should be cleanly cut to length. The length required should be measured from the top of the tank (where the sensor is to be mounted) to that of the fuel outlet point (as shown).



**Note:** The bottom of the pipe should be a minimum of 5cm from the base (floor) of the tank to prevent it from touching in the case of tank dimensional changes due to temperature etc.

- The waveguide pipe should be securely attached via the two grub screws and hand tightened with an M1.5 Allen key (Note: over-tightening the grub screws can damage the plastic). Care should be taken to keep the sensor and pipe vertically aligned and supported, while fitting during the installation.

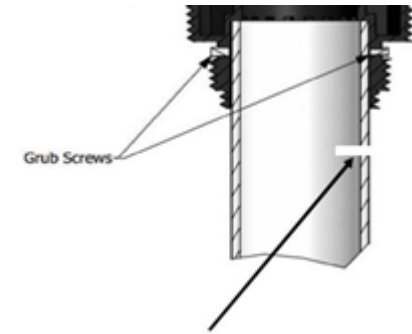

Air escape vent hole (2mm diameter)

**Note:** Depending on the weight, length and surface finish of the pipe, it may be necessary to glue it into position. In this case a hole should be drilled near the top of the waveguide pipe, just below the adaptor, to ensure that any trapped air can exit.

- Insert the correctly sized rubber seal ring, as required for the tank opening (supplied), and position it on the face of the adaptor that is screwed onto the top of the tank.



- Insert the whole assembly carefully into the tank, taking care not to loosen the pipe, and fit into position. Hand tighten the assembly until the rubber seal locks into position.

### Appendix 5: Drilling procedure for Multi-Thread adaptor.

- Set up Multi-Thread adaptor as indicated in Appendix 3.
- Choose a flat spot on the top of the tank.
- Use a 45.5mm tapping drill to drill a 1 ½" BSP hole on the surface of the tank.
- Place the foam gasket over the hole followed by the mounting adaptor.
- Tighten on to tank with 2 stainless steel self-tapping, counter sunk screws, supplied. Do not over tighten!
- Screw the sensor into the adaptor. Ensure that the sensor is vertical on the tank and screwed correctly into the base and that the threads have not crossed, to give a secure seal.

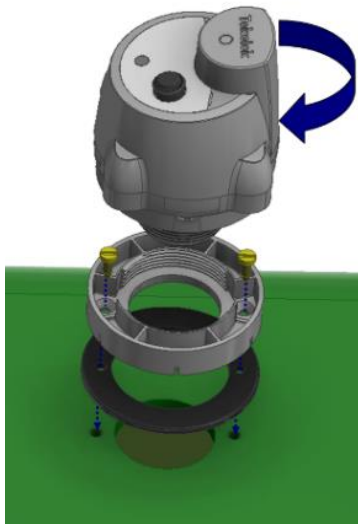

### Appendix 6: External Antenna

The external antenna should be elevated and clear of near obstacles for best performance. The antenna should be mounted on a magnetic surface (at least 15cm<sup>2</sup> area) for best performance. The antenna requires self-amalgamating tape to seal the antenna cable joint - Note: This cable joint, while water resistant, should not be submerged in water.

Please see the Tekelek YouTube channel for video instruction.

- Cut 300mm of 'Tesa' (provided) self-amalgamating tape.

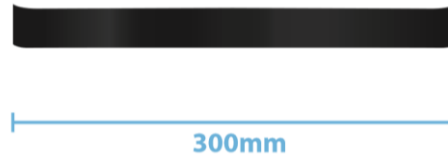

- After fitting in the required site location, connect the SMA connector from the Antenna to that of the sensor.



- Start wrapping the tape 70cm away from the SMA connection. The tape needs to be kept in tension by stretching and the clear plastic backing of the tape should be unwrapped as the installation proceeds.

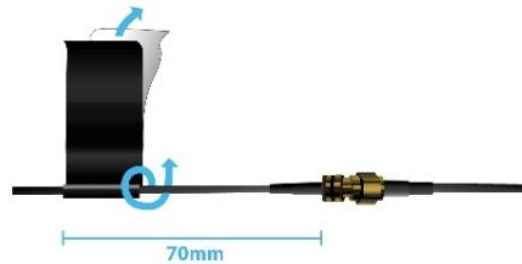

- Keep the tape stretched while wrapping, over-lapping half the width of the previous turn.

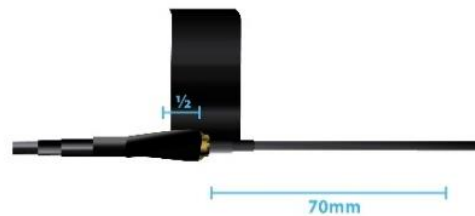

- Continue to wrap the tape to a distance of 70cm on the other side of the SMA connector. Then reverse the direction and continue to wrap back along to the starting point. Note: the tape must be stretched for best performance.



- See the sensor with sealed SMA connections (see the following picture). Excess cable can be looped and tie-wrapped as shown.



- The antenna should be placed vertically (upwards or downwards) on a magnetic surface (larger than 15cm<sup>2</sup> area for best performance).



- A P-clip (highlighted in the picture below) is supplied to secure the antenna cable and keep the sealed joint away from any standing water.



For more information on the Tekelek Ultrasonic LoRaWAN sensor please visit our website [www.tekelek.com](http://www.tekelek.com) where a link to our YouTube page can also be found.